

# Simultaneous Registration of Contraction and Cytosolic Calcium ( $[Ca^{2+}]_i$ ) of Smooth Muscle Strips Using Front-Surface Fluorimetry

Alice T. Ferreira,<sup>1,3</sup> Rogerio Neri,<sup>1</sup> Maria E. M. Oshiro,<sup>1</sup> and Hideo Kanaide<sup>2</sup>

Received September 28, 1999; revised February 9, 2000; accepted February 11, 2000

Using front-surface fluorimetry with fura-2-loaded smooth muscle strips, simultaneous registration of the cytosolic calcium concentration ( $[Ca^{2+}]_i$ ) changes and tension development was done under the action of 40 mM KCl and the myotropic peptide  $10^{-6}$  M angiotensin II. The strips were mounted vertically, connected to a force transducer that keeps a basal isometric tension of 0.5 g, and maintained in a bathing solution oxygenated at 37°C. The fiber-optic platform FluoroMax-2 accessory 1950F was used to do the remote sensing for the samples. Light from the excitation spectrometer (FluoroMax-2), alternating between 340 and 380 nm, was focused onto the fiber-optic bundle and directed to the smooth muscle strip. The fluorescence (505 nm) was collected and redirected to the emission port of the fluorimeter FluoroMax-2. The ratiometric method (R340/380) was used as an index of  $[Ca^{2+}]_i$  change during smooth muscle contraction. All data, R340/380 and tension, were recorded using a computerized data acquisition system: Soft & Solution and GRAMS/386 of Galactic Industries Corporation.

**KEY WORDS:** Fura-2; front surface; smooth muscle; cytosolic calcium.

## INTRODUCTION

The calcium ion plays an important role in cellular signalization, specifically to induce smooth muscle contractile responses. During the contraction induced by receptor-mediated stimulation, however, there is a temporal relationship between  $[Ca^{2+}]_i$  and the developed tension for which the molecular and cellular mechanisms in intact smooth muscle must be clarified. Therefore, it is important to measure  $[Ca^{2+}]_i$  and tension simultaneously. For this purpose, front-surface fluorimetry of fura-2, a

$[Ca^{2+}]$  indicator dye [1], has been performed on small smooth muscle strips by Kanaide *et al.* since 1990 [2,3],

The first group to use this approach with success, to monitor the naturally occurring fluorescence of intact tissue (rat heart), was Chance *et al.* in 1972 [4] and 1976 [5]. The principle of this technic is that the distance between the excitation light source, the detector of the emitted light, and the tissue is reduced, allowing a more accurate detection of the emission light.

According to the scheme in Fig. 1, in our front-surface fluorometer there are bifurcated quartz optic fibers where the excitation lights are guided from the fluorometer source through the optic fibers arranged in an inner circle, and the emission light is collected from the sample by the optic fibers arranged in an outer circle and guided to the photomultiplier detector of this fluorometer. The entire front surface of the sample can be illuminated by this way, and almost the whole fluorescence

<sup>1</sup> Department of Biophysics, Universidade Federal de São Paulo (UNIFESP)/Escola Paulista de Medicina, São Paulo, Brazil.

<sup>2</sup> Division of Molecular Cardiology, Institute of Angiocardiology, Faculty of Medicine, Kyushu University, Fukuoka, Japan.

<sup>3</sup> To whom correspondence should be addressed at Rua Botucatu 862, São Paulo, Brazil, CEP 04023-062. Fax: 55-11-571-5780. e-mail: alice@biofis.epm.br

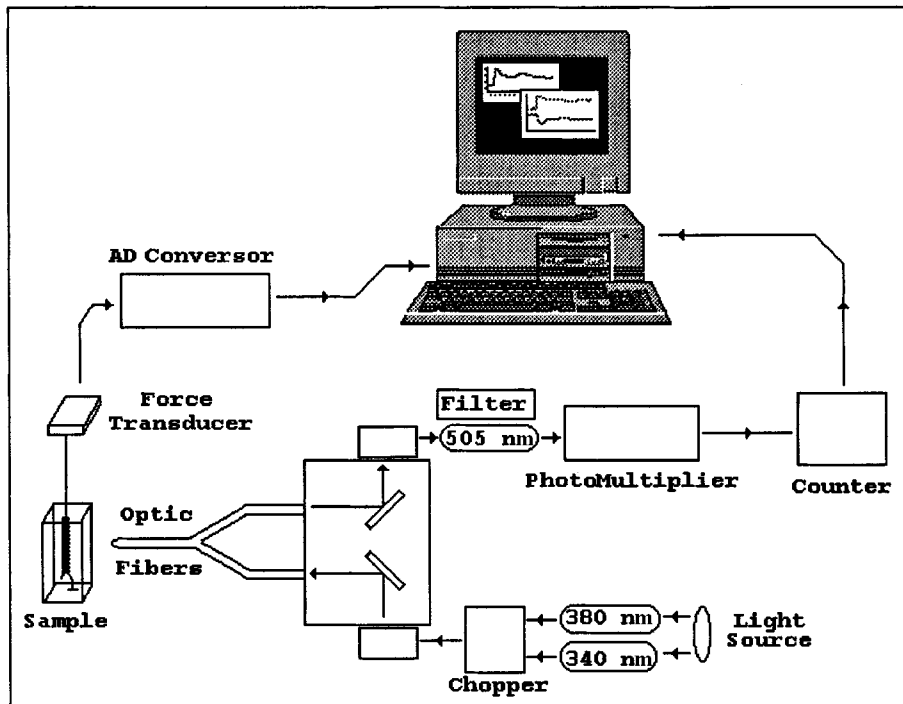

Fig. 1. Scheme of the front-surface fluorimetry for fura-2 using the FluoroMax-2 spectrofluorometer.

signal from the front surface can be detected since the optic fibers are very close to the smooth muscle strip.

The fura-2 indicator dye was used because, first, it has an excellent quantum yield, allowing measurement of changes in  $[Ca^{2+}]_i$  of the order of  $10^{-9} M$  when it complexes with this ion ( $K_d = 224 nM$  *in vitro*) [1]; second, the ratiometric measurement of two excitation wavelengths (340 and 380 nm) cancels the parallel changes in the intensities of the two emitted light (F340 and F380) signals induced by the moving artifact produced by contraction (shortening, torsion) of the smooth muscle strip; and, third, it permits exclusion of the changes in autofluorescence correlated with the NAD/NADH fluorescence changes that occur during the contraction of smooth muscle [6]. Therefore, the ratio between the fluorescence intensities at 340-nm excitation and 380-nm excitation ( $R_{340/380}$ ) obtained with front-surface fura-2 fluorescence simply indicates the changes in  $[Ca^{2+}]_i$  of the smooth muscle cells and is not a result of artifacts owing to either contraction or movement of the tissue. There are potential complications of calibration, such as intracellular compartmentalization and binding of fura-2 to intracellular proteins, so the equation proposed by Grynkiewicz *et al.* to calculate  $[Ca^{2+}]_i$  [1] gives only an approximation of the true value. Accurate quantification of  $[Ca^{2+}]_i$ , although desirable, usually is

not strictly necessary for the interpretation of the results, and the data can be presented as the fluorescence ratio.

## MATERIAL

(1) The  $[Ca^{2+}]_i$  indicator dye fura-2/AM [mol = 1002; an acetoxymethyl (AM) form of fura-2] was from Molecular Probes (Eugene, OR) and from Sigma Chemical Co. (St. Louis, MO). Small plastic tubes in special packing containing fura-2/AM dry powder, 50  $\mu g$  or 1 mg each, were stored at  $-20^\circ C$ .

(2) Guinea pigs of either sex, weighing 300–400 g, were killed by decapitation. A 20-cm portion of terminal ileum was removed and washed at room temperature with Tyrode solution of the following composition (mM): 137 NaCl, 2.68 KCl, 1.36  $CaCl_2$ , 0.49  $MgCl_2$ , 12  $NaHCO_3$ , 0.36  $NaH_2PO_4$ , and 5.6 D-glucose. During the experiments the tissues were maintained in this solution at  $37^\circ C$  and bubbled with a mixture of 95%  $O_2$  and 5%  $CO_2$ , pH 7.6. After separation from the mucosa, longitudinal muscle strips about 5 mm wide and 15 mm long were mounted in Tyrode solution under a tension of 0.5 g in an attachment designed for simultaneous measurement of the  $[Ca^{2+}]_i$  and contraction (Fig. 2A).

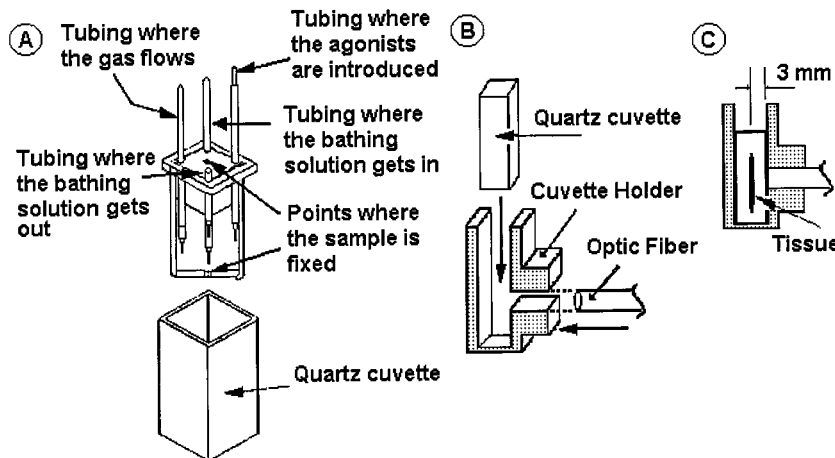

Fig. 2. (A) Tissue analysis attachment that is installed in the quartz cuvette, which is inserted inside the single-position thermostated cell holder with a magnetic stirrer. (B, C) The position of the optic fiber with respect to the quartz cuvette and the muscle strip.

(3) The tissue analysis attachment is installed inside a quartz cuvette with 2.5 ml of Tyrode solution connected to a solution feed pipe and drain pipe; the flow is controlled in such a way that when the bathing solution is changed, no turbulence occurs. The gas is fed through the gas feed pipe with small bubbles. If the gas flow rate is high, the preparation will be shaken by a large amount of big bubbles, causing adverse effects to the tension and fluorescence measurements. Through a fourth entry, a syringe guide, small quantities (50  $\mu$ l, at most) of agonist solutions are introduced in the bathing solution.

(4) The quartz cuvette with the tissue attachment is introduced inside a single-position thermostated cell holder with a magnetic stirrer (FluoroMax-2 accessory 1962; Fig. 3). With polyethylene tubing the respective connections are done, and through a cotton thread the smooth muscle strip is connected to a strain gauge transducer (TF 03; Ampere-Eletro-Eletronica Ltda., São Paulo) to monitor the isometric tension.

(5) This cell holder is inside a casket that contains two opposite holes: one of them is a window through which the position of the strip is checked and placed straight in front of the other hole, where the optic fiber is fixed at a distance of 3 mm from the muscle strip (Figs. 2B and C).

(6) The fiber-optic platform FluoroMax-2 accessory 1950F was used, which was developed to do remote fiber sensing for samples that cannot be positioned in a conventional sample chamber, in the region between 250 and 850 nm.

(7) A constant cell holder temperature of 37°C is maintained through the pumping-water circulating thermostatic bath from Soft & Solutions (São Paulo). A spec-

trofluorometer FluoroMax-2 (ISA Jobin Yvon-SPEX Instruments S.A., USA) with a front-surface detection accessory 1950F and a bifurcated fiber probe, which both direct exciting light to the smooth muscle strip area and collect the resulting fluorescence, was remodeled into a front-surface fluorometer. The fluorometer source is a xenon lamp, with the bulb mounted vertically, focused onto the entrance slit of the excitation monochromator with an elliptical mirror. The slits themselves are bilaterally, continuously adjustable from the computer in units of bandpass (wavelength) or millimeters. The spectrofluorometer has two monochromators: one of them is used to select the excitation wavelengths (alternating between 340 and 380 nm), and with the other the emission wavelength (505 nm) is chosen. The emission detector electronics employs photon counting for the ultimate in low-light level detection. Photon counting concentrates on signals that originate from fluorescence photons, ignoring the small pulses originating from the photomultiplier tube electronics. It also contains an integral high-voltage supply, which is factory set to provide the maximum count rate, while eliminating most of the dark noise. The emission slit is adjusted to 10 mm to get the most efficient counting of the emitted photons from the sample. The FluoroMax software Multi Group Scanning permits the selection and monitors the two excitation wavelengths, 340 and 380 nm, and the emission wavelength, 505 nm.

(8) All data (F340, F380, R340/380, and tension) were recorded using a computerized data acquisition system: Soft & Solution, GRAMS/386 (Galatic Industries Corp., USA), and GemPower 4515 (TriGem Computer, Inc., Fremont, CA). An example of the simultaneous

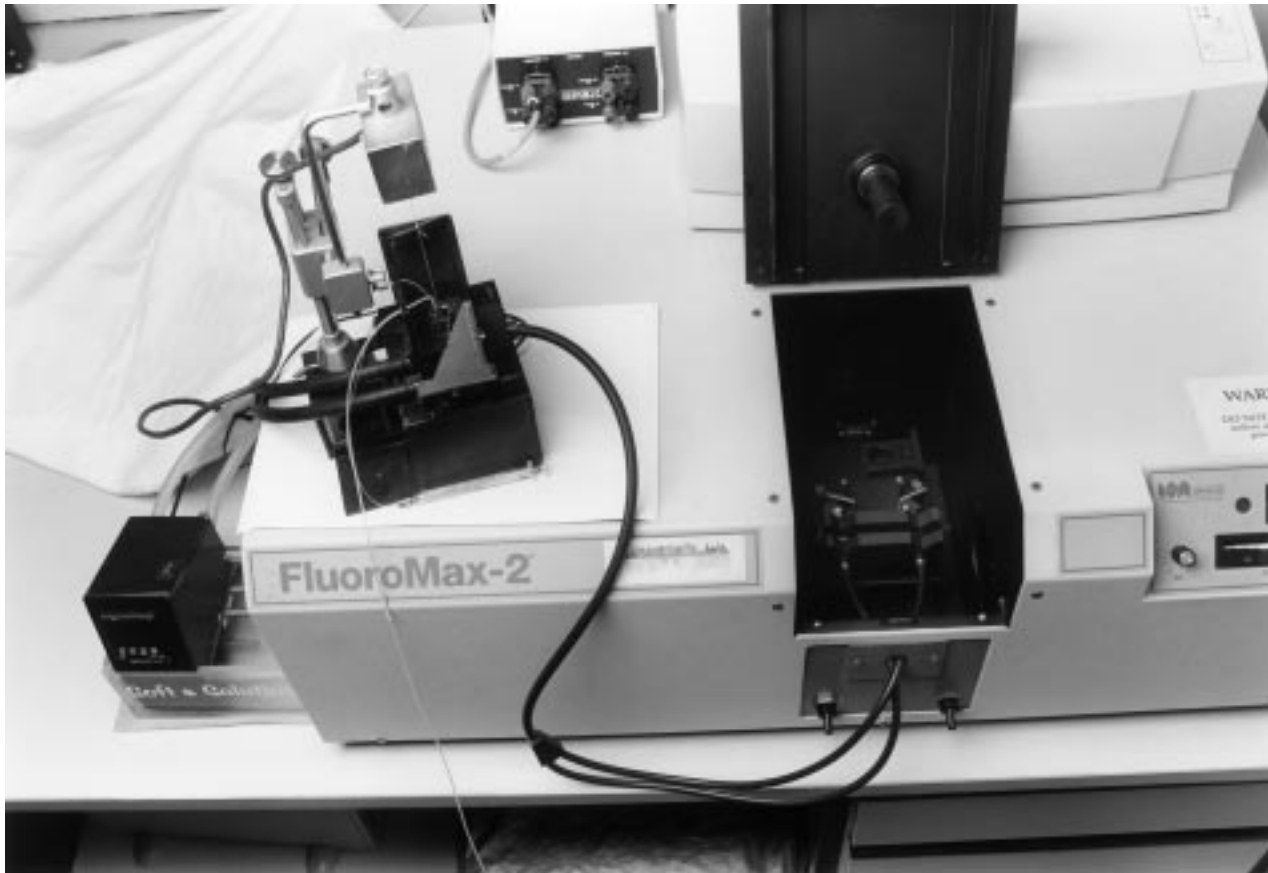

**Fig. 3.** The front-surface fluorimetry setup showing the FluoroMax-2 spectrofluorometer with the spacious sample chamber where the 1950 fiber optic platform is installed (at right), from which emerges the fiber-optic bifurcated bundle. The fiber-optic bundle has the end connected to a casket, which is over the fluorometer single-position thermostated cell holder with magnetic stirrer. Inside the latter accessory is the quartz cuvette with the tissue analysis attachment. The smooth muscle strip is connected by one of the ends, through a cotton thread, to a TF 03 force transducer, to the left of the casket. To the left of the fluorometer is the circulating thermostated bath (Soft & Solution).

registration of tension (upper trace) and R340/380 (lower trace) is shown in Fig. 4.

## METHODS

### Fura-2 Loading

(1) Fura-2/AM powder, 50  $\mu\text{g}$  or 1 mg, was dissolved in 50  $\mu\text{l}$  or 1 ml of dimethyl sulfoxide (DMSO) and then 10  $\mu\text{l}$  of it was dissolved in 2.5 ml of Tyrode solution (final concentration, 4  $\mu\text{M}$ ) and sonicated for 5 min. To get easier and homogeneous loading of fura-2, 10  $\mu\text{l}$  a 10% pluronic F127 was added (final concentration, 0.04%).

(2) Smooth muscle strips mounted vertically in the tissue analysis attachment were introduced inside a quartz cuvette containing 2.5 ml of Tyrode solution and, after

all tubing connections were installed, were introduced inside the casket, which contains the single-position thermostated cell holder with magnetic stirrer. Through a cotton thread, one of the ends of the sample was connected to the force transducer, which maintains a basal isometric tension of 0.5 g, and the casket was then closed. The fluorescence excitation spectra between 300 and 400 nm were determined to get the autofluorescence values of the tissue. This autofluorescence is due to pyridine nucleotide (reduced form), flavoproteins, or cytochromes and is essentially related to energy metabolism. Usually they give low fluorescence values compared with the fura-2-loaded strips (less than 10%). The fluorescence quantum yield of the complex fura-2-Ca is so high that the autofluorescence of the tissue is easily overcome. It must be subtracted when it is larger than 10% of the value obtained with fura-2-loaded tissue. KCl (40 mM) is introduced in the bathing solution to see if the preparation is responding

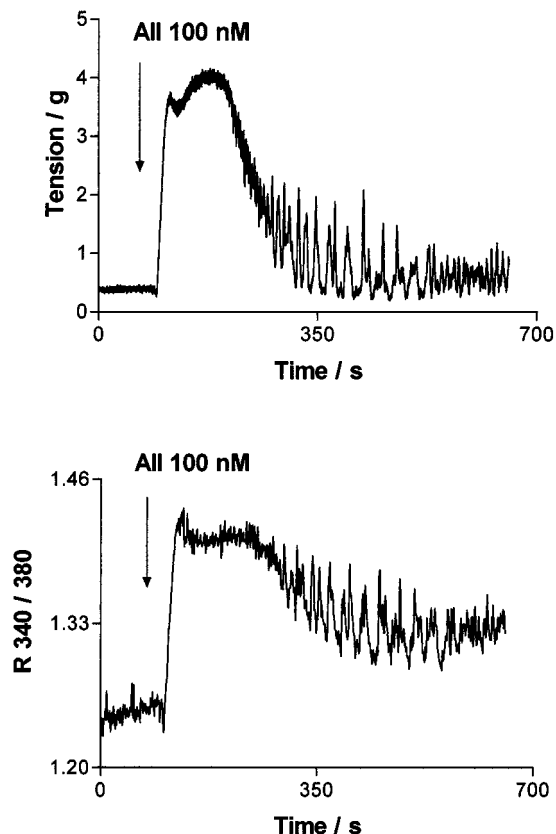

**Fig. 4.** Typical simultaneous registrations of contraction (upper trace) and cytosolic calcium, given by the ratio F340/F380 (R340/380, lower trace), of a longitudinal layer (smooth muscle) of guinea pig ileum under the action of myotropic peptide angiotensin II (AII; 100 nM), at 37°C. The smooth muscle strip was loaded with fura-2 (incubated with 4  $\mu$ M for 2 h, at room temperature). R340/380 is the ratio between the fluorescence intensities of the emitted lights by the sample, at 505 nm, when alternately excited at 340 and 380 nm.

to this general depolarization stimulus and if no artifact is being introduced in the R340/380 by changes of autofluorescence, or torsion of the preparation, during the contraction of the unloaded strip.

(3) The bathing solution was replaced by one containing fura-2/AM (4  $\mu$ M), and another excitation spectra was determined to confirm the presence of the dye and if it was at a good concentration. Maintained in oxygenated loading Tyrode solution at room temperature, it was incubated for 1 h. The incubation time depends on the tissue, being 4 h, for example, for arterial strips and rat vas deferens.

(4) After each hour of incubation the fluorescence excitation spectra were registered to see, by the shift of the maximum emission-excitation (that is, 390 nm for fura-2/AM and 350 nm for fura-2-Ca complex), if the tissue was loaded with fura-2. Once the maximum around

350 nm was obtained, the preparation was washed with normal, oxygenated Tyrode and the thermostatic bath turned on, keeping the temperature of the preparation at 37°C during the experiments. Another spectrum excitation was registered to see if the sample was loaded with fura-2 (Fig. 5). To test the responsiveness after dye loading, 40 mM KCl was added to the bathing solution. If the contractile response was similar to the initial one and if the difference between the fluorescence of the fura-2-loaded sample and the autofluorescence was reasonably high, the experiments were started (Fig. 5).

(5) In some strips it was necessary to add 4 mM probenecid or 250  $\mu$ M sulfinpyrazone to block the export of fura-2 from the cells, inhibiting their anion transport [5]. We observed that probenecid has contradictory effects on  $[Ca^{2+}]_i$  and on the contractile response to some agonists, sulfinpyrazone being the best blocker of this preparation.

#### MEASUREMENT OF ISOMETRIC TENSION DEVELOPMENT AND FRONT-SURFACE FLUORIMETRY

Simultaneous determination of tension and changes in the fluorescence emission, F340 nm and F380 nm, from the entire front surface of the fura-2-loaded smooth muscle strips at 37°C was done, in oxygenated Tyrode solution, kept inside a quartz cuvette, in a thermostated cell holder with a magnetic stirrer, and this whole system was kept inside a casket with a remote optic fiber connected to the fluorimeter. The advantage over the Kanaide first systems [3] is that it is not necessary to work in a darkroom since the strip holder, optic fibers, etc., are inside a casket, avoiding background fluorescence owing to any possible extraneous signal. The ratio R340/380 was calculated using the DataMAX for Windows software

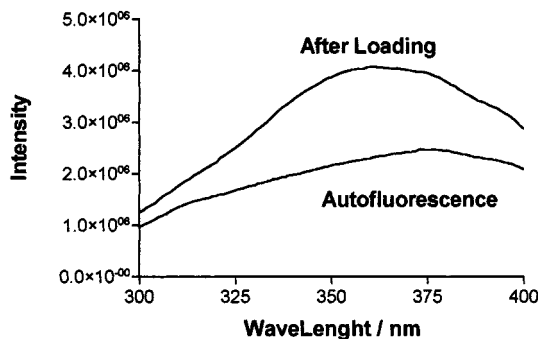

**Fig. 5.** Excitation spectra in the interval 300–400 nm of a smooth muscle strip before (autofluorescence) and after loading with fura-2; emission at 505 nm.

GRAMS/386 and put together with the tension registered simultaneously using the Soft & Solutions software.

At the end of the experiment the  $R_{\max}$  (fura-2-Ca<sup>2+</sup> saturated; giving a maximal F340/F380 ratio of 1.54) was obtained by adding 0.1 mM digitonin, which permeabilizes the cellular membrane when it combines specifically with the membrane cholesterol. To be sure that the registered signals came from the fluorescence of the fura-2-Ca<sup>2+</sup> complex, 2 mM MnCl<sub>2</sub> was added. The Mn<sup>2+</sup> has a higher affinity for fura-2 than Ca<sup>2+</sup>, and it displaces the latter ion, forming the complex fura-2-Mn, whose fluorescence intensity at 340–380 nm is less than 1% of that obtained in the presence of Ca<sup>2+</sup> [7]. The ions Ca<sup>2+</sup> and Mn<sup>2+</sup> combine only with the acidic form of fura-2, so when quenching of the fura-2 fluorescent signal by the addition of Mn<sup>2+</sup> to the preparation is observed, it assures that the registrations obtained previously really correspond to changes of [Ca<sup>2+</sup>]<sub>i</sub> and are not results of artifacts produced by the fluorescent ester forms of fura-2, which do not bind Ca<sup>2+</sup>. Finally, 4 mM EGTA is added and it chelates Ca<sup>2+</sup> and Mn<sup>2+</sup> so the free fura-2 fluorescence intensity at 340–380 nm is obtained and  $R_{\min}$  can be calculated (1.00). The values of  $R_{\max}$  and  $R_{\min}$  can be used to estimate [Ca<sup>2+</sup>]<sub>i</sub> using the Grynkiewicz equation [1] that is included in the FluoroMax software (DataMax software for Windows). It has been noted, however, that the [Ca<sup>2+</sup>]<sub>i</sub> values obtained are only an approximation of the true [Ca<sup>2+</sup>]<sub>i</sub> values since the  $K_d$  of fura-2-Ca changes according to the proteic composition of the cytoplasm [8].

Some care must be taken when using front-surface fluorimetry to study the cytosolic calcium–force relationship: first, a high intensity of excitation (ultraviolet) light can cause tissue injury, mainly when loaded with fura-2 (photodynamic effect), and photobleaching of the fluorescent dye can occur, so it is necessary to avoid experiments with a long time course; second, the incubation time and the concentration of fura-2/AM for fura-2 loading depend on the preparation. If the intracellular concentration of fura-2 is too high, it can disturb the registrations by Ca<sup>2+</sup>-buffering action; and, finally, Kanaide *et al.* [9] have demonstrated for arterial smooth muscle preparations that the resting load regulates the cytosolic calcium–force

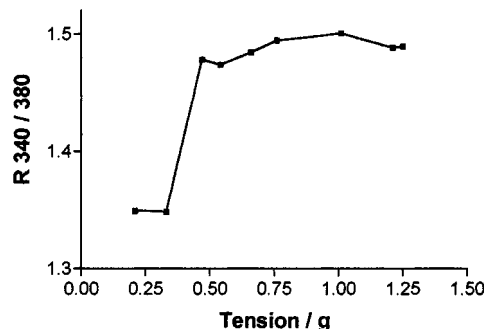

Fig. 6. Relationship between isometric tension development and measurement of R340/380 for guinea pig ileum smooth muscle.

relationship, being necessary to determine the effects of a change in the preload or resting load, on this relationship for each kind of smooth muscle preparation to get accurate results (Fig. 6).

#### ACKNOWLEDGMENTS

This work was done with the technical assistance of Nelson A. Mora and was supported by grants from Fundação de Amparo à Pesquisa do Estado de São Paulo (FAPESP) and Conselho Nacional de Desenvolvimento Científico e Tecnológico (CNPq).

#### REFERENCES

1. G. Grynkiewicz, M. Poenie, and R. Y. Tsien (1985) *J. Biol. Chem.* **269**, 3440–3450.
2. K. Hirano, H. Kanaide, S. Abe, and M. Nakamura (1990) *Br. J. Pharmacol.* **101**, 273–280.
3. H. Kanaide (1999) in D. G. Lambert (Ed.), *Methods in Molecular Biology*, 114, 269–277, Human Press Inc., Totowa, NJ.
4. B. Chance, I. A. Salkovitz, and A. G. B. Kovach (1972) *Am. J. Physiol.* **223**, 207–218.
5. H. Frank, C. H. Barlow, and B. Chance (1976) *Am. J. Physiol.* **231**, 1082–1089.
6. H. Ozaki, K. Sato, T. Satoh, and H. Karaki (1987) *Jpn. J. Pharmacol.* (1987) **45**, 429–433.
7. C. Y. Kwan and J. W. Putney, Jr. (1990) *J. Biol. Chem.* **265**, 678–684.
8. J. W. M. Bassani, R. A. Bassani, and D. M. Bers (1993) *J. Physiol.* **460**, 603–621.
9. Y. Miyagi, S. Kobayashi, J. Nishimura, M. Fukui, and H. Kanaide. (1995) *J. Physiol.* **484**, 123–137.